



Installation and Assembly Instructions

Parts List

Part #	Part	Quantity
1	Base Stand Assemblies	2
2	Arm Assemblies	2
3	Spring Assemblies including Safety Sleeve	2
4	Line Assemblies	2
5	Shoulder Bolt with Nut and Washers	2

Assembling the Wake Watcher

STEPS:

1. Unpack and check contents. A complete packing list of all parts is included in the kit.
2. Using the Shoulder Bolt – insert the Arm Assembly into the Yoke of the Base Stand Assembly. Tighten the Nut securely - Figure 1.
3. Attach the Line Assembly securely to the end of the Arm Assembly - Figure 2.
4. Insert the longer (lower) Spring eye bolt through the hole in the base of the Base Stand Assembly – follow the diagram – and securely tighten the nut - Figure 2.
5. Insert the other Spring eye bolt into the selected hole in the Arm Assembly – and securely tighten the nut - Figure 2.

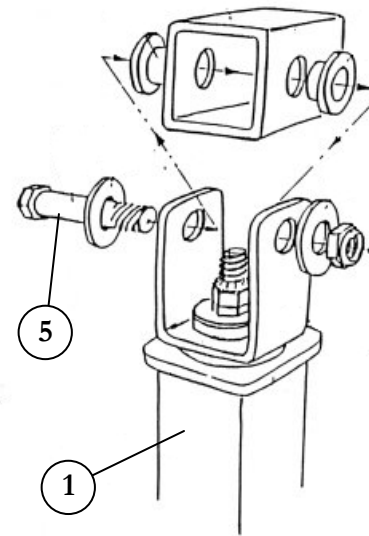

Figure 1
Arm to Yoke and
Base Stand Assembly

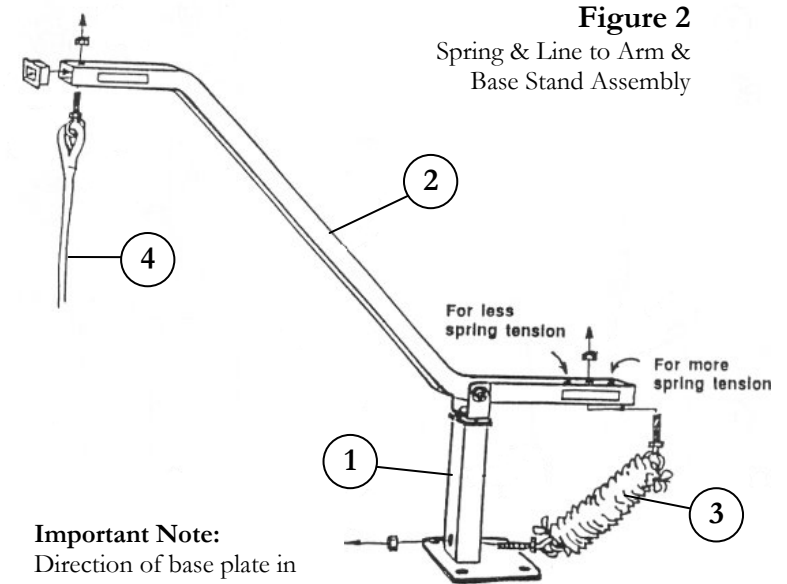

Figure 2
Spring & Line to Arm &
Base Stand Assembly

Important Note:
Direction of base plate in
relation to Arm and Spring

NOTES:

- the three holes allow you to select different tensions on the Spring assembly. The closest hole to the Base Stand pivot point has the least tension.
- Spring Sleeves are longer than the Springs and are clumped to fit over the Spring. The sleeve will straighten as the Spring expands. To install, see Figure 3.
- ***It is very important to use the Spring Safety Sleeve!*** Serious personal injury could result from not using the Spring Safety Sleeves. Spring coils open and close with wave actions, and when the Wake Watcher™ Arms are released from your Boat. This opening and closing action of the Springs could pinch fingers or flesh if not covered and protected by the Spring Safety Sleeve.

6. You are now ready to install the Wake Watcher Assemblies to your Dock.

Fastening Wake Watcher™ Assemblies to your dock:

Determine the distance between the Arm Assemblies by measuring the distance between the cleats on your boat and adding 18 inches. It is recommended that the arms angle in towards each other by approximately 15 degrees. Another way of determining this distance is to add approximately 9 inches toward the outside of the boat cleats - Figure 4. This spacing will keep the arms under constant tension and keep the boat centered.

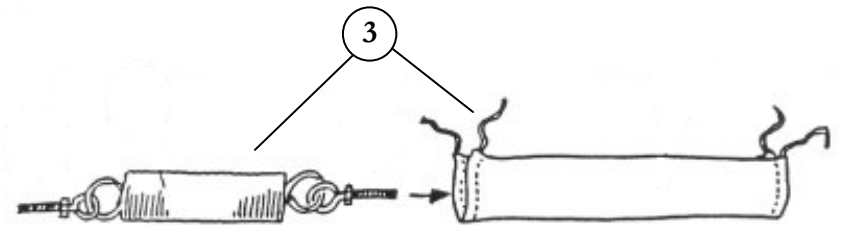

Figure 3
Spring and Safety Sleeve Assembly
ESSENTIAL SAFETY EQUIPMENT
(See Warning in Notes section)

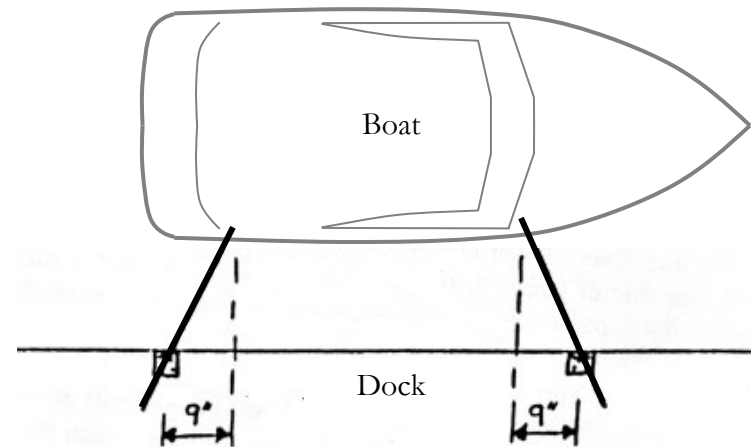

Figure 4

Note: The mounting connection of the Wake Watcher™ Boat Mooring System to your Dock is very important and must be strong and secure. Dock fasteners have not been supplied due to the many variations of docks. We recommend that you use grade A bolts, washers and lock nuts when bolting down the ‘System. If necessary, reinforce the appropriate areas of the dock.

Fastening your Boat to Wake Watcher™ Boat Mooring System:

When fastening your Boat to the Wake Watcher™ Boat Mooring System, it is important that the back portion of the Arm Assemblies be level or parallel to the dock and 90 degrees to the base stand - Figure 5. It is important that these instructions are followed or the ‘System will not perform properly. We recommend that you use your boat bumpers until you have determined the correct tension adjustment for optimum performance. We **STRONGLY** recommend that you use spring lines or cross tie your boat in adverse wind, wave and weather conditions - Figure 6. It is also recommended that you cross tie your boat when leaving it moored for extended periods of time - Figure 6.

Warranty null and void if instructions are not followed.

